

บอลวาล์วสามชิ้นเกลียว / ชนเชื่อม

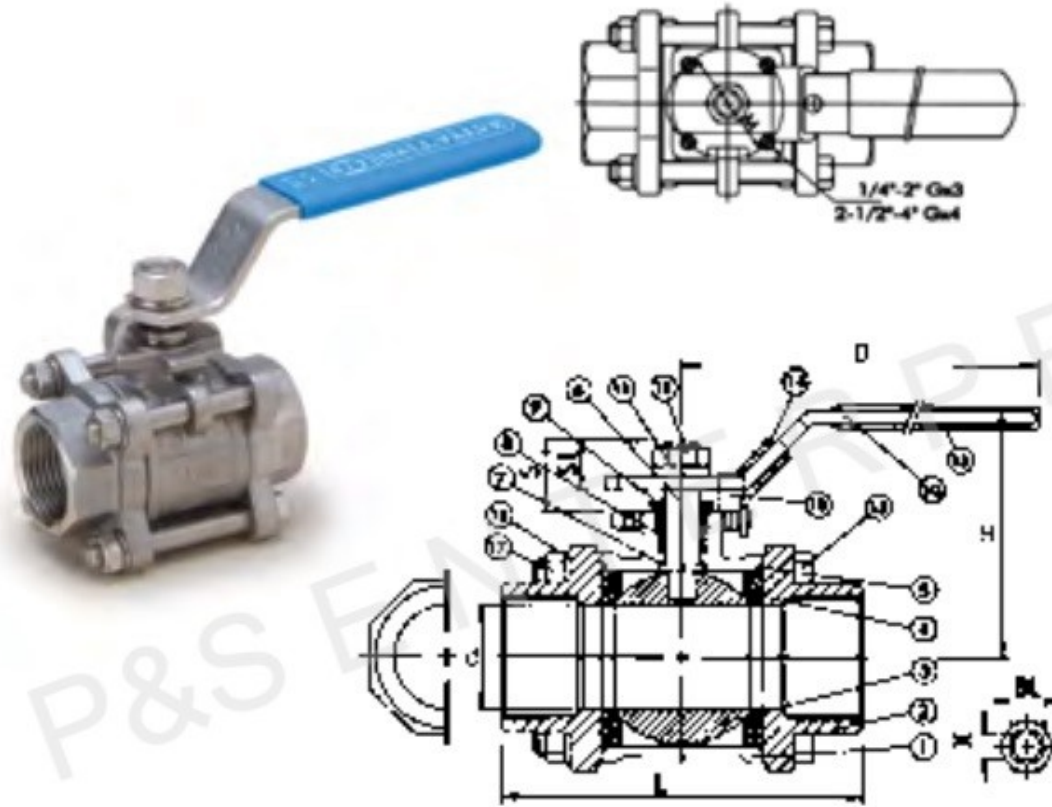

- * Screwed End, Butt Weld End
- * The available THREAD: ANSI B2.1, BS21 or DIN-259.
- * Blow-Out Proof Stem / Full Port.
- * Investment Casting Body and Cap.
- * Locking Device, Lug Body.
- * 1000PSI (69BAR) W.O.G. / 1500PSI (103BAR) W.O.G.

Material

	Model	V-3
1	Body	CF8M
2	Cap	CF8M
3	Ball	CF8M
4	Ball Seat	PTFE
5	Joint Gasket	PTFE
6	Stem	AISI 316
7	Thrust Washer	PTFE
8	Stem Packing	PTFE
9	Gland Nut	AISI 304
10	Handle	AISI 304
11	Stem Washer	AISI 304
12	Stem Nut	AISI 304
13	Plastic Cover	PLASTIC
14	Lock Device	AISI 304
15	Bolt	AISI 304
16	Spring Washer	AISI 304
17	Hex Nut	AISI 304

Dimension

Size	inch	1/4	3/8	1/2	3/4	1	1.1/4	1.1/2	2	2.1/2	3	4
	mm	8	10	15	20	25	32	40	50	65	80	100
Bore Size		11.6	12.7	15	20	25.4	32	38.1	50.8	65	80	100
L		65	65	66	81	95	109	129	150	180	206	261
H		51	51	55	60	74	80	92	101	130	142	174
D		95	95	95	110	135	135	165	165	215	215	325
Torque kgf/cm		40	40	54	78	106	150	200	280	500	770	1100