

Investment casting, ASTM-A351, CF8M, Class 600,
Screwed Cap, Swing type disc, Integral Seat.

สวิงเช็ควาล์วสแตนเลส 316 เกลียา

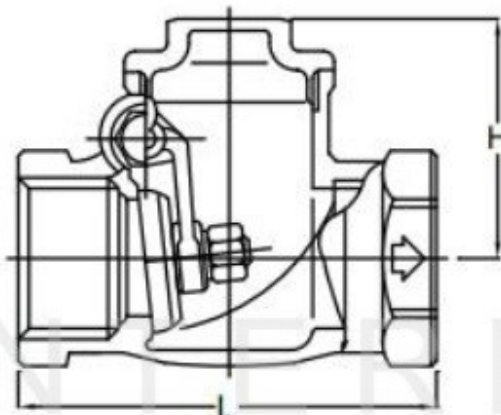

- * Connecting threads screwed ends to BS21 basically, ANSI B2.1 and DIN 259 are available when required.
- * Pressure Temperature Rations 600 PSI, WSP/350°F.

Hydrostatic Test Pressure

Shell 21 kg/cm²
Seat 6 kg/cm² (AIR)

Dimension

mm

Size	inch	1/2	3/4	1	1.1/4	1.1/2	2	2.1/2	3
	mm	15	20	25	32	40	50	65	80
L		60	78	84	94	104	122	153	175
H		41.5	46	49	53.5	58.5	67	105	125
Weight/kgs		0.29	0.53	0.69	0.85	1.2	1.8	3.5	5.0

Material

	Model	SS-209
1	Body	CF8M
2	Disc	CF8M
3	Disc Nut	AISI 304
4	Connecting Rod	CF8M
5	Pin	AISI 304
6	Bolt	AISI 304
7	Bolt Washer	TEFLON
8	Gasket	TEFLON
9	Cap	CF8M